



APX 5.0-30.0P-S0 High Voltage Battery System

User Manual

About this Document

This document introduces the APX 5.0-30.0P-50 Battery System (short for APX) in terms of installation, electrical connection, operation, commission, maintenance, and troubleshooting. Before installing and operating the APX system, ensure that you are familiar with product features, functions, and safety precautions provided in this document.

Symbol	Description
 WARNING	Indicates a potentially hazardous situation, if not avoided, could result in serious injury or death.

Table of Contents

1 Product Overview	1
1.1 Intended Use.....	1
1.2 Appearance	1
1.2.1 APX 55027-P0 (Power Module).....	1
1.2.2 APX 5.0P-B1 (Battery Module).....	4
1.3 Working Principle and Function.....	5
2 Safety.....	6
2.1 General Safety	6
2.2 Safety Precautions.....	6
2.2.1 Environment requirements	6
2.2.2 Operation Precautions.....	7
2.3 Label Description.....	7
2.4 Emergency Responses.....	9
3 Storage and Transportation.....	10
3.1 Storage Requirements	10
3.2 Transportation Requirements.....	10
4 Installation	11
4.1 Basic Installation Requirements.....	11
4.2 Installation Tools	13
4.3 Installation Procedures	14
4.3.1 Pre-installation Check	14
4.3.2 Wall-mounted Installation	16
4.3.3 Floor-mounted Installation.....	19
4.4 Electrical Connection	22
4.4.1 Communication port definition	22
4.4.2 System connection	23
5 Power on/off the APX Battery System.....	30
5.1 Power on the APX Battery System	30
5.2 Power off the APX Battery System.....	32

6 Maintenance Guide..... 33

- 6.1 Preparation 33
- 6.2 Replace a fuse..... 33
- 6.3 Battery Module or Power Module replacement..... 33
- 6.4 LED indicators 34
- 6.5 Troubleshooting..... 35
- 6.6 System fault information list and troubleshooting suggestions 37
- 6.7 Cleaning 44

7 Technical Specifications 45

- 7.1 APX 55027-P0 (Power Module) 45
- 7.2 APX 5.0P-B1 (Battery Module) 45

1 Product Overview

1.1 Intended Use

The entire APX 5.0-30.0P-50 high-voltage energy storage system is composed of a APX 55027-P0 (hereinafter referred to as Power Module) and multiple APX 5.0P-B1 battery modules (hereinafter referred to as Battery Module, the maximum number of Battery Module connected in parallel is 6).

Each Battery Module consists of 100Ah LFP battery cells and a DC-DC converter, which boosts a power source of 51.2V up to 380V. One to six Battery Modules can be connected in parallel to increase the capacity and power of the energy storage system.

The APX battery system powers the loads through the Single-phase hybrid inverter MIN2.5-6KTL-XH/MIN2.5-6KTL-XH2 whenever demanded; when solar becomes available during daytime, solar energy powers the loads as a priority and the surplus solar power is stored into the APX battery system.

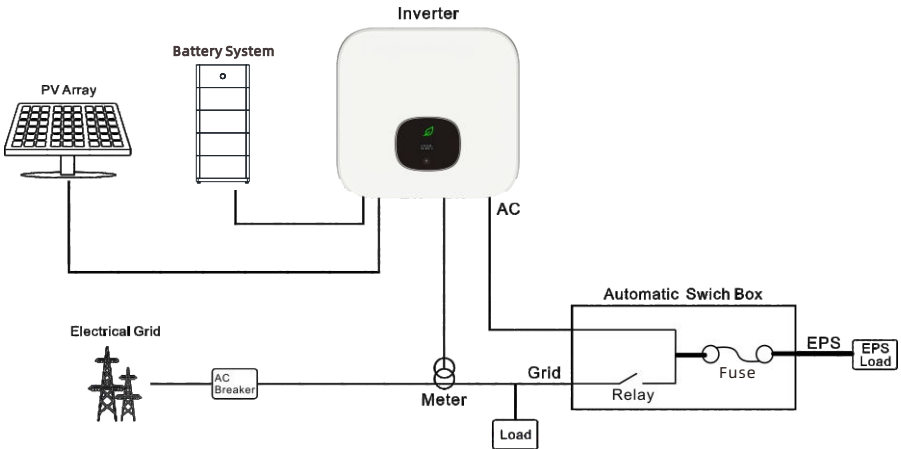

Figure 1-1: System diagram of APX high voltage battery system

1.2 Appearance

1.2.1 APX 55027-P0(Power Module)

Power Module is composed of power control units, relay, fuse, DC switch, power supply and communication terminals. The appearance of the product is shown below.

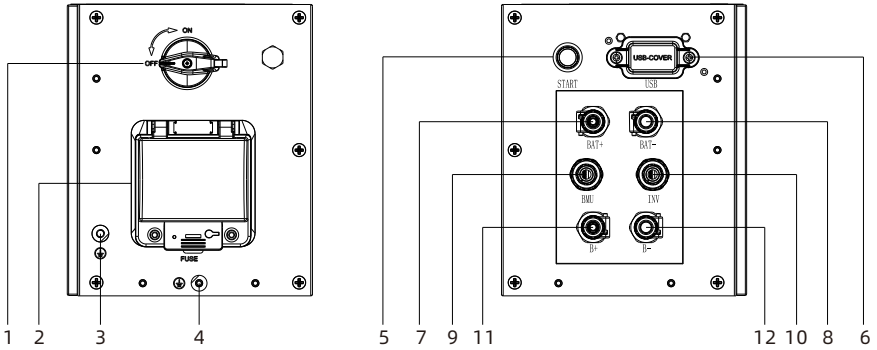



Figure 1-2: Schematic diagram of power panel

Location	Port	Function
1	DC switch	Turn on/off the power connection between the Power Module to the hybrid Inverter
2	FUSE	Provide overcurrent protection for a circuit
3		Ground terminal, connect to the hybrid inverter
4		Ground terminal, connect to the Battery Module
5	Start	Wake up the Battery Module (Press for over 5 seconds)
6	USB	USB port, connect to a USB flash drive to upgrade firmware
7	BAT+	The positive output from the APX system to the hybrid inverter
8	BAT-	The negative output from the APX system to the hybrid inverter
9	BMU	Port for communication with the Battery Module
10	INV	Port for communication with the hybrid inverter
11	B+	Connect to the positive power terminal of the Battery Module.
12	B-	Connect to the negative power terminal of the Battery Module.

LED display

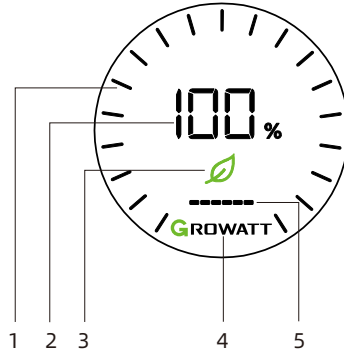

Figure1- 3: LED display

No.	Function	Function description
1	Display SOC	Display current SOC in a progress circle
	Display upgrade status	Eight light bars rotate clockwise when the program is updating
	Charging	When charging, light bars light up one by one clockwise
	Discharging	When discharging, light bars go off one by one anticlockwise
2	Display SOC	Display SOC in percentage
	Display upgrade status	When upgrading the program, "UP" is displayed
3	Power Module status indicator	Steady green during normal operations; Blinking green indicates an alarm or the standby mode;Blinking red due to a fault;
4	Logo	The light is steady on when the APX is on
5	Battery Module status indicator(Each bar represents one BM)	Steady green during normal operations; Blinking green to generate an alarm; Steady red due to a fault;

Dimensions (unit: mm)

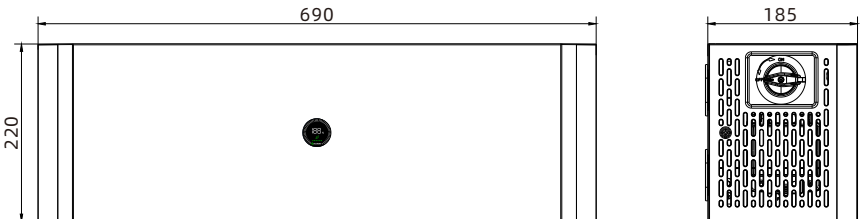

Figure 1-4: Dimensions of APX 55027-P0

1.2.2 APX 5.0P-B1 (Battery Module)

Battery Module consists of LFP battery cells, a DC-DC converter, mechanical parts, the battery management unit (BMU) as well as power and communication terminals. Product appearance is shown as below.

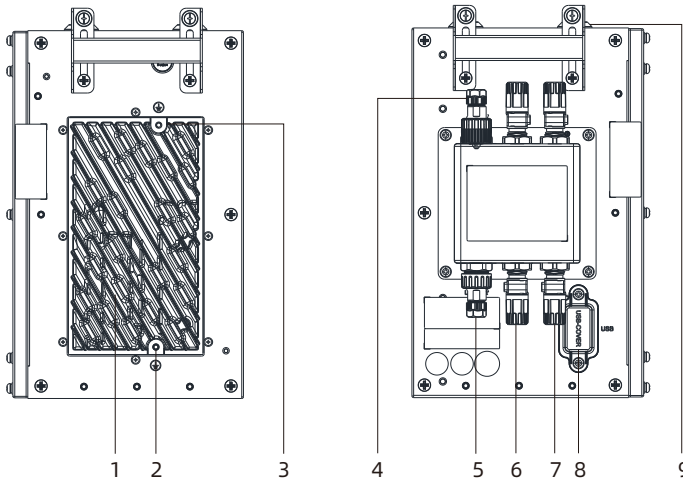



Figure 1-5: Schematic diagram of the power panel

Location	Port	Function
1	Heat sink	DC-DC converter heat sink
2		Ground terminal, connect to the next module
3		Ground terminal, connect to the pervious module
4	Link in	Communicate with the previous module
5	Link out	Communicate with the next module
6	B+	Positive battery cascading terminal B+
7	B-	Negative battery cascading terminal B-
8	USB	USB port, connect to a USB flash drive to upgrade firmware
9	Stacking guide component	Module alignment

Dimensions (unit: mm)

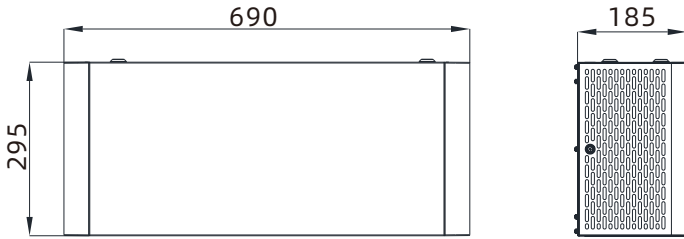

Figure 1-6: Dimensions of APX 5.0P-B1

1.3 Working Principle and Function

The APX 5.0-30.0P-50 high voltage battery system is composed of a Power Module APX 55027-P0 and multiple Battery Modules APX 5.0P-B1 connected in parallel. It contains electrochemical batteries, battery control units, power control units, battery management units, power and signal terminals, and mechanical parts. The APX distinguishes itself with better charging and discharging performance, higher charging and discharging efficiency, higher flexibility in capacity expansion, more accurate status monitoring, longer service life, and less self-discharge loss.

The APX system can connect 1 to 6 Battery Modules in parallel to increase the capacity and power of the battery system; The APX system communicates with the hybrid inverter through RS485 communications.

- **Monitoring:** Monitor the voltage, current and temperature of each battery module and the battery system.
- **Protection and Alarm:** Generate alarms and provide protection in cases of overvoltage, undervoltage, overcurrent, over-temperature or under-temperature.
- **Report:** Report alarms and status data to the hybrid inverter.
- **Parallel connection:** Support the parallel connection of one to six Battery Modules.
- **Battery cell balancing:** passive battery balancing.
- **Battery Module balancing:** intelligent power distribution, active balancing
- **System power-off:** 12 minutes after the communication between the battery system and the hybrid inverter is disconnected.

Safety 2

When installing or using a battery system, observe the safety precautions provided in this section. For personal safety, the operation personnel must read through this manual and observe the safety instructions.

2.1 General safety

The battery system has been designed and tested in accordance with strict rules to meet international safety certification requirements. Before installing or using the battery system, please read all safety instructions carefully and observe the rules. Growatt will not be liable for any consequence of the following circumstances:

- Damage during the transportation by the customer.
- Damage caused by improper operations in transportation, storage, installation and use, or the third party fails to convey the correct information about transportation, storage, installation and use to end users.
- Improper installation by unprofessional and unreliable personnel.
- Failure to follow the operation instructions and safety precautions in this document.
- Unauthorized modifications or removal of the software package.
- The product's tamper evident label is removed or any item is missing due to customer's negligence or intentional damage.
- Operation in environments that cannot meet the requirements specified in this document.
- Damage caused by repairing, disassembling, and modifying PACKs without authorization.
- Damage to labels on the chassis or modification on the date of production.
- Battery packs fail to be charged for more than six months.
- Damage due to force majeure, such as lightning, earthquakes, fire, and storms.
- Warranty expiration.

2.2 Safety Precautions











2.2.1 Environment requirements



- Do not expose the battery to temperature above 50°C or heat sources.
- Do not install or use the battery in wet environment with moisture, corrosive gases or liquids, such as in the bathroom.
- Do not expose the battery to direct sunlight for extended periods of time.
- Place the battery in a safe place and ensure that the battery is not accessible to children and animals.
- Battery power terminals shall not come in contact with conductive objects such as wires.
- Do not place the battery in a fire, which may cause an explosion.
- The battery system must be protected from liquids.

2.2.2 Operation Precautions

- Do not touch the battery system with wet hands.
- Do not disassemble the battery system without authorization.
- Do not crush, drop or pierce the battery pack and the high voltage controller.
- Dispose of the batteries according to local safety regulations.
- Store and recharge the battery in accordance with this manual.
- Ensure that the PE cable is securely connected.
- Remove all metal objects such as watches and rings that could cause a short circuit before installation, replacement and maintenance.
- The Pack shall be repaired, replaced or maintained by qualified and well-trained personnel.
- When storing or handling the batteries, do not stack batteries without package.
- Handle the battery with caution to avoid leakage. The leaked electrolyte is toxic and hazardous to skin and eyes.
- Stack battery packing cases in compliance with the stacking requirements on the external package.
- Do not use damaged, faulty or deformed batteries, which may release flammable gases that may cause a fire or other safety hazards.

2.3 Label Description

Symbols	Description
	Do not dispose of the system with the household waste but in accordance with the local regulations
	Lithium-Ion batteries can be recycled
	The system complies with the requirements of the applicable EU directives.
	Be aware of the electric shock
	Be aware of the explosive gas
	Be aware of the battery leak
	Heavy objects. Lift with care
	Keep the Pack away from children
	Ensure that the positive and negative terminals are correctly connected
	Keep away from open flame or ignition sources
	Observe the manual

 GROWATT APX High Voltage Battery System	
System Model/ Nominal Voltage/ Nominal Power/ Nominal Energy/ Rated Energy/	<input type="checkbox"/> APX 5.0P-S0/ 450d.c.V/2.5kW/ 5kWh/4.5kWh <input type="checkbox"/> APX 10.0P-S0/ 450d.c.V/5kW/ 10kWh/9kWh <input type="checkbox"/> APX 15.0P-S0/ 450d.c.V/6.2kW/ 15kWh/13.5kWh <input type="checkbox"/> APX 20.0P-S0/ 450d.c.V/6.2kW/ 20kWh/18kWh <input type="checkbox"/> APX 25.0P-S0/ 450d.c.V/6.2kW/ 25kWh/22.5kWh <input type="checkbox"/> APX 30.0P-S0/ 450d.c.V/6.2kW/ 30kWh/27kWh
High Voltage Controller Model	APX 55027-P0
Protective Class	I
Max. Current	17A
Peak Current	27A,60s
Ingress Protection	IP66
Operating Ambient Temperature	-10°C ~ +50°C
 X Made in China	



GROWATT	Name : Battery Module Model : APX 5.0P-B1	
Battery Type : Li-ion Nominal Energy : 5kWh Rated Energy : 4.5kWh Input/Output : 330-450V;7.6A;2.5kW Peak Output Current : 12.5A,60s Protective Class : I Battery Interface : Isolated Ingress Protection : IP66 Weight : 50kg Operation Ambient Temperature : -10°C-+50°C		
 X Made in China		

Figure 2-1: Nameplate



Figure 2-2: Label

 WARNING	<p>Performance de-rate may be initiated when the temperature is below 10°C</p>
---	--

2.4 Emergency Responses

Manufacturer has taken foreseeable risk scenarios into consideration and designed the battery system to mitigate the hazards. In case of an emergency, do as below:

Emergency	Description and measures
Leakage emergency	<p>➤ Avoid contact with leaked liquids or gases. Should you come into direct contact with the battery electrolyte, do as follows:</p> <p>Inhalation: Evacuate from the contaminated area, and seek immediate medical attention.</p> <p>Eye contact: Flush your eyes with flowing water for 15 minutes, and seek immediate medical attention.</p> <p>Skin contact: Wash the affected area with soap and water, and seek immediate medical attention.</p> <p>Ingestion: seek immediate medical attention.</p>
Fire emergency	<p>Normally, the battery system won't ignite spontaneously. If a fire occurs, do not try to extinguish the fire but evacuate people immediately.</p>
Flood emergency	<p>If the battery system is soaked or submerged in water, do not touch the batteries to avoid electric shock. Contact Growatt or your distributor immediately for technical assistance.</p>
Shell damage	<p>The shell damage requires extra attention as it is of high risk. Do not use batteries with a damaged shell, which may cause safety hazards. Contact Growatt or a distributor to dispose of them.</p>

Storage and Transportation 3

3.1 Storage Requirements

- Place the batteries according to the signs on the packing case.
- Do not put batteries upside down or on their side.
- Do not store damaged batteries near undamaged ones.
- The storage environment requirements are as follows:
 - Install the batteries in a dry, clean and well-ventilated place.
 - Recommended storage temperature: 40°C to 50°C (storage period: one week); -20°C to 40°C (storage period: 6 months).
 - Relative humidity: 5% to 95% RH.
 - Do not expose batteries to corrosive environments.
 - Avoid direct exposure to sunlight and rain.
 - Keep the batteries at least two meters away from heat sources (such as a radiator).
 - Avoid exposure to intense infrared radiation.



NOTICE

If the battery pack is not used for more than six months, carry out a charging cycle every six months.

3.2 Transportation Requirements

The battery pack passes the certifications of the UN38.3 (Section 38.3 of the sixth Revised Edition of the Recommendations on the Transport of Dangerous Goods: Manual of Tests and Criteria) and SN/T 0370.2-2009 (Part 2: Performance Test of the Rules for the Inspection of Packaging for Exporting Dangerous Goods). The battery pack belongs to Class 9 dangerous goods.

- The battery pack shall not be transported with other inflammable, explosive or toxic materials.
- Ensure that the original package and label are intact and identifiable.
- Avoid direct exposure to sunlight, rain, condensing water caused by temperature difference and mechanical damages.
- Do not pile up more than four Battery Modules.
- There will be a drop in capacity during transportation and storage.
- Transportation temperature is between -20°C to 40°C, relative humidity: 5%~95%RH.

4 Installation

	<p>WARNING</p> <ul style="list-style-type: none">➤ Read through the Guidance before installation to understand product information and safety precautions;➤ Only qualified and well-trained technicians who fully understand the whole photovoltaic system, grid network, battery system, working principle and national/local standards are allowed to perform operations on the battery;➤ Installers must use insulating tools and wear safety equipment;➤ Device damages caused by failure to comply with storage, transportation, installation and use requirements specified in Guidance are not covered under any Warranty.➤ Do not install or use the battery near explosive or inflammable materials.➤ Use the battery in a well-ventilated environment with temperature ranging from -10°C to 50°C . For outdoor installation, build a sun & rain shade to avoid direct exposure to sunlight and rain.➤ The batteries should be protected from dust and dirt. Do not expose batteries to high humidity.
--	---

4.1 Basic Installation Requirements

➤ The battery system can be installed indoors or outdoors. The angle and space requirements are as follows:

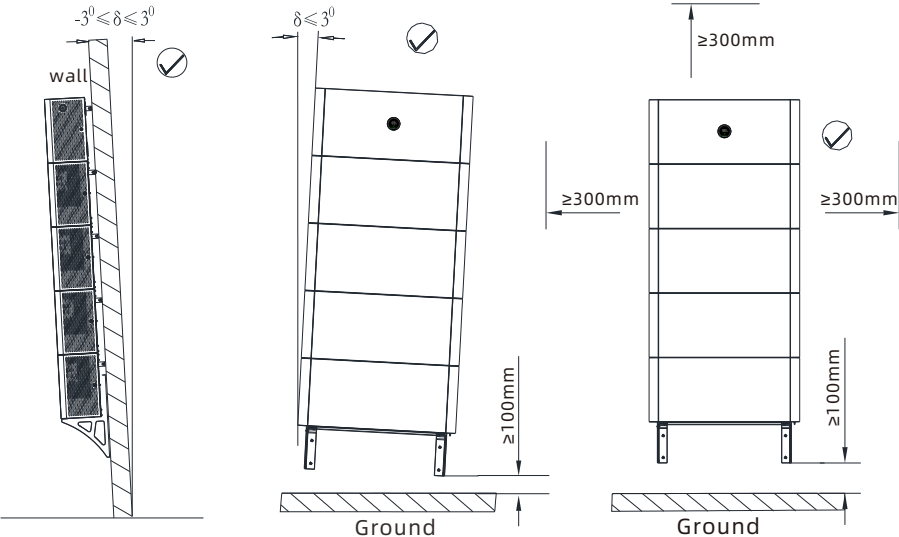

Figure 4-1: Wall-mounted installation

Note: When mounted on the wall, a maximum of six battery modules can be configured.

If the number of the battery modules to be installed is greater than four, you are advised to install them in 2 columns.

Ensure that the load-bearing capacity of the wall exceeds the total weight of the system (PM weighs 10 kg and each BM weighs 50 kg).

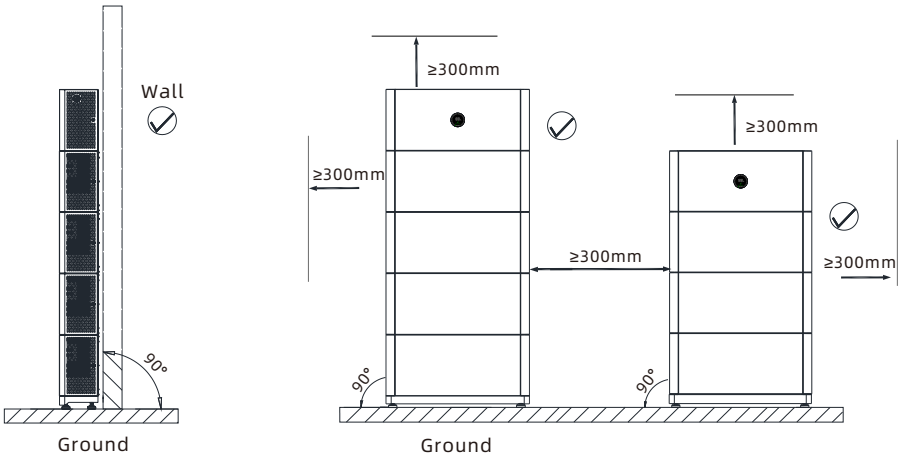

Figure 4-2: Floor-mounted installation

Note: For the floor-mounted installation with the base, a maximum of six battery modules can be configured.

If the number of the battery modules to be installed is greater than four, you are advised to install them in 2 columns.



WARNING

Do not place the battery pack upside down.

➤ When installed outdoors, build a sun/rain shelter to protect the battery system from direct sunlight and rain.

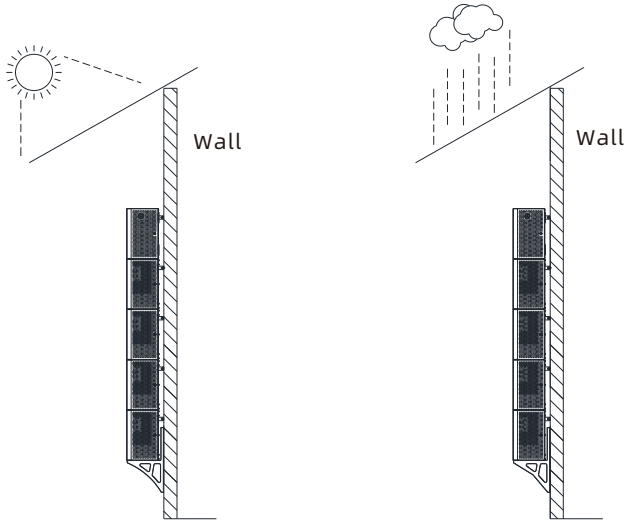
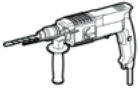



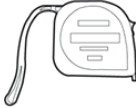



Figure 4-3: Build a sun/rain shelter

4.2 Installation Tools

Prepare the following tools to install the battery system:

 <p>M6 Drill</p>	 <p>M4-1N·m Screwdriver</p>	 <p>M6-2N·m Socket Wrench</p>
 <p>Pencil</p>	 <p>Tap Measure</p>	 <p>Multimeter</p>

It is recommended to wear the personal protective equipment when operating the battery system.

 <p>Insulated Glove</p>	 <p>Safety Goggle</p>	 <p>Safety Shoes</p>
--	--	---

4.3 Installation Procedures

4.3.1 Pre-installation Check

- Check the package before unpack it. If any damage is found, do not unpack the package and contact your distributor.
- Check the quantity of all components according to the package list. If any damage is found or any component is missing, please contact your distributor.

4.3.1.1 Check the APX Battery System of different capacities

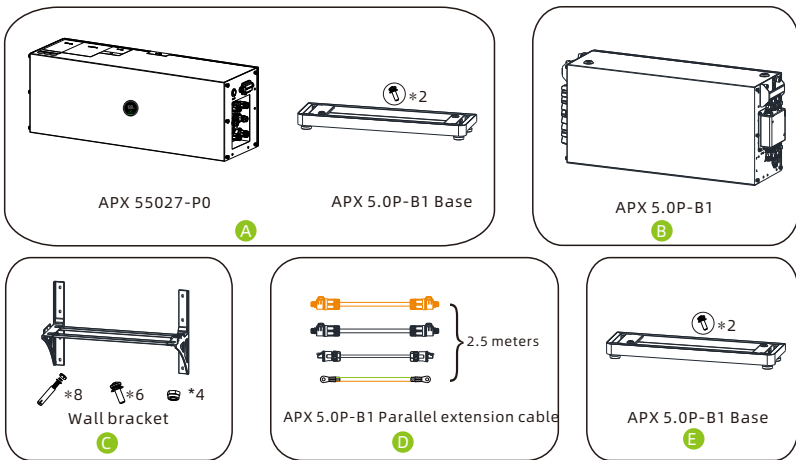

Figure 4-4: Components of the APX Battery System of different capacities

Battery System Capacity	Standard Wall-Mounted Installation Compound Mode	Standard Floor-mounted Installation Compound Mode
5kwh	A+B+C	A+B
10kwh	A+B*2+C	A+B*2
15kwh	A+B*3+C	A+B*3
20kwh	A+B*4+C	A+B*4
25kwh	A+B*5+C*2+D	A+B*5+E+D
30kwh	A+B*6+C*2+D	A+B*6+E+D

4.3.1.2 Check the components of the APX 55027-P0

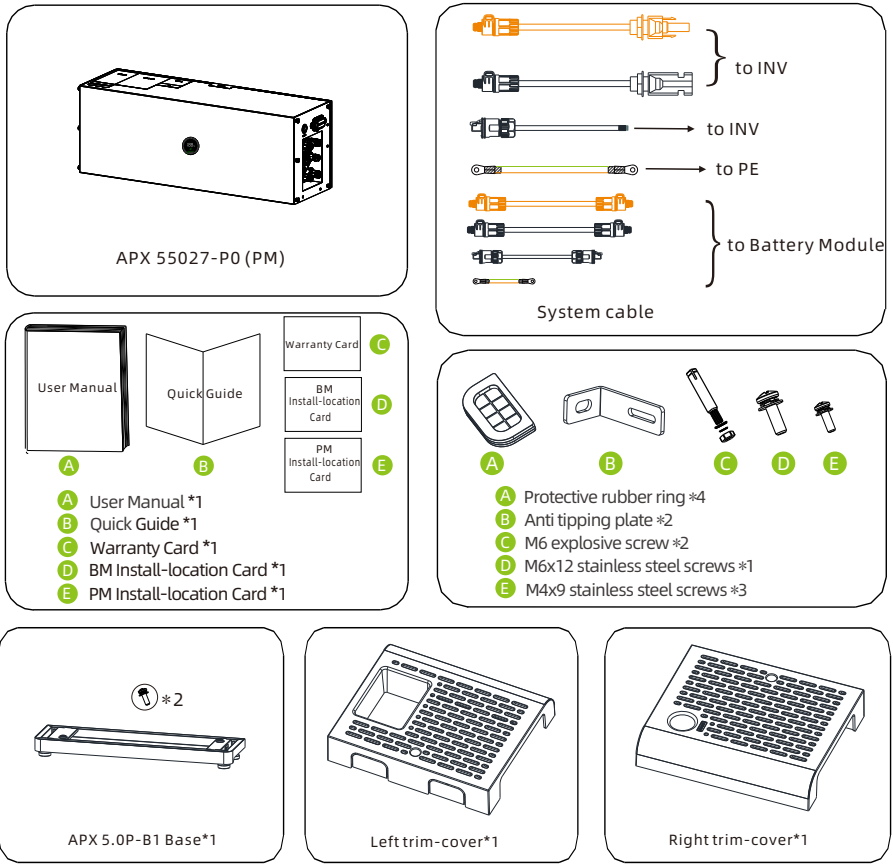
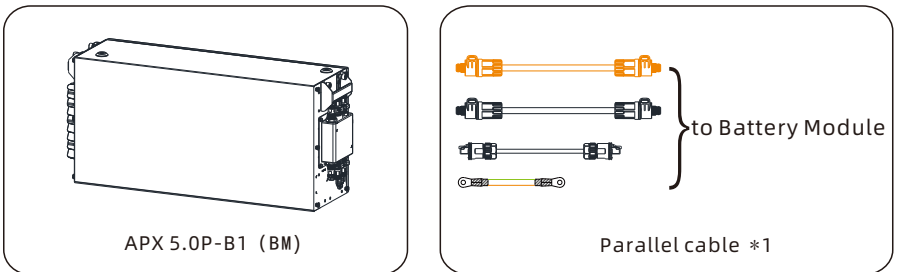

Figure 4-5: Components of the APX 55027-P0

4.3.1.3 Check the components of the APX 5.0P-B1



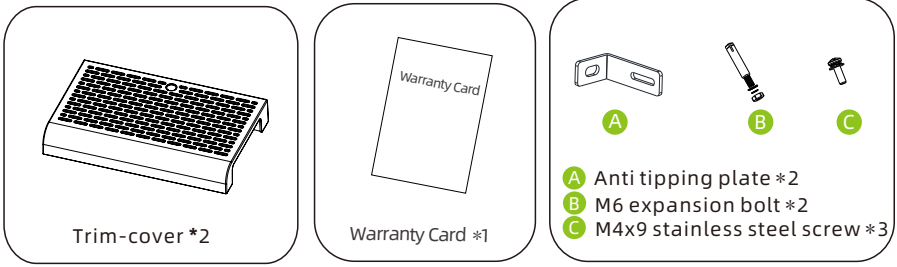



Figure 4-6: Components of the APX 5.0P-B1

 NOTICE	<ul style="list-style-type: none"> ➤ Ensure that you have the standard accessories - the Power Module (APX 55027-P0) and the Battery Module (APX 5.0P-B1) . The APX battery system consists of a Power Module (APX 55027-P0) and 1 to 6 Battery Modules (APX 5.0P-B1). ➤ The support base or the mounting bracket is optional based on the installation method. ➤ If you want to install one APX battery system in two columns, you need to purchase a parallel extension cable separately.
--	--

4.3.2 Wall-mounted Installation

Mounting Hole Dimensions

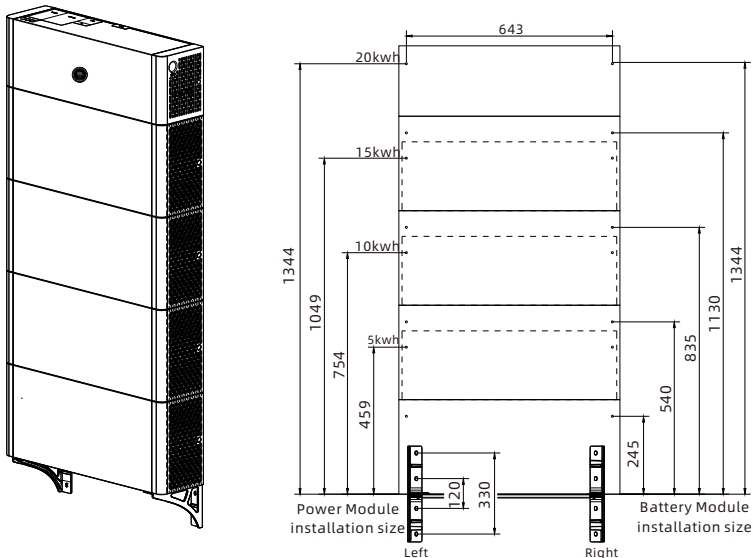

Figure 4-7: Mounting Hole Dimensions

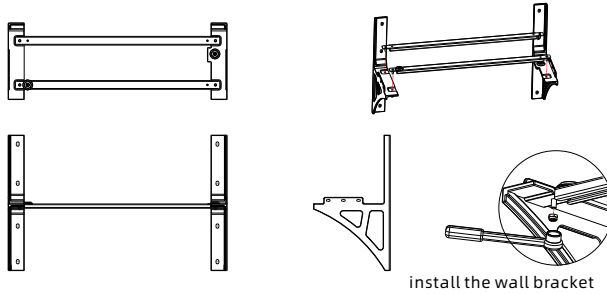

Figure 4-8: Install the mounting bracket

Step 1: Install the mounting bracket.

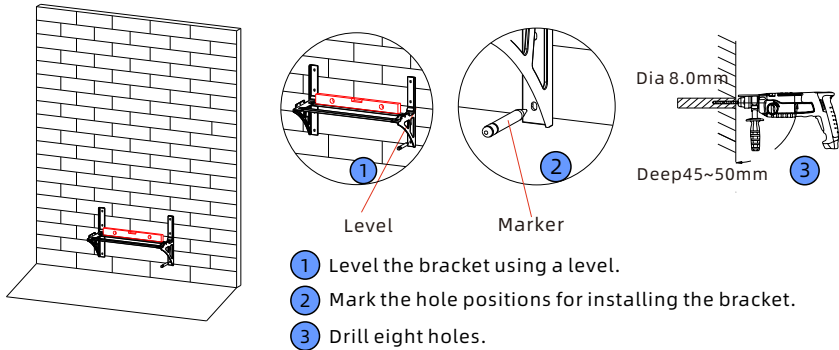

Figure 4-9: Determine the hole positions for installing the bracket

Step 2: Level the bracket using a level, and mark the hole positions for installing the bracket using a marker. Drill 8 holes (alloy drill diameter: 8mm; hole depth: 45mm to 50mm).

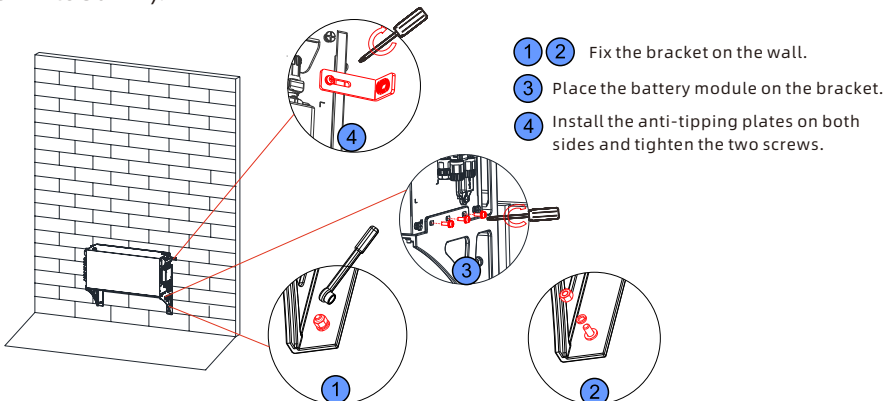
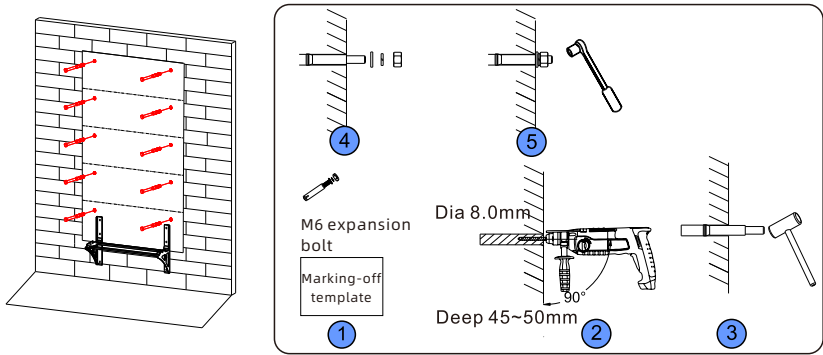

Figure 4-10: Fix the bracket to the wall

Step 3: Fix the wall bracket on the wall and place the first battery module on the mounting bracket. Install the anti-tipping plates on both sides and tighten the two screws. Mark the hole positions for installing the first battery module.



- ① The marking-off template ensures that the alignment marks are properly placed on the wall.
- ② ③ ④ ⑤ Fix the M6 expansion bolt into the wall.

Figure 4-11: The marking-off template and install the expansion bolt

Step 4: Remove the battery module, determine the hole positions to mount the battery modules from bottom to top using the marking-off template, mark the hole positions using a marker. Install the M6 expansion bolts.

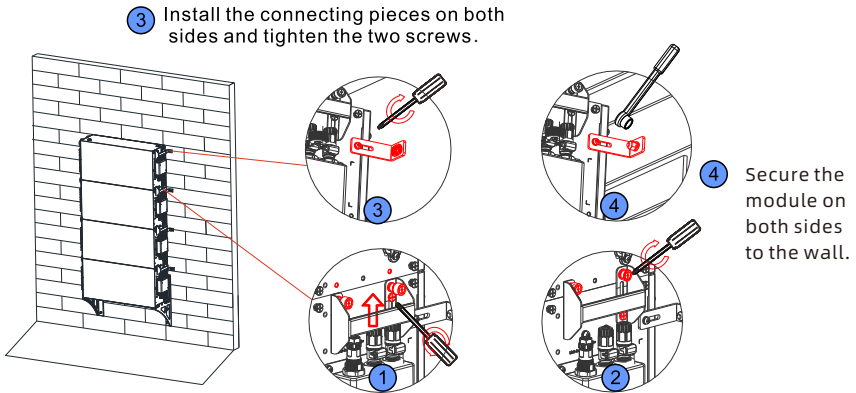

- ③ Install the connecting pieces on both sides and tighten the two screws.
- ① Loosen two screws, move up handle on both sides.
- ② Tighten the two screws, fix the two battery modules.

Figure 4-12: Install the battery module

Step5: Install the remaining battery modules (no more than 4 of them), raise the handles on both sides, tighten the two screws that secure the battery module. Install the connecting pieces on both sides and tighten the two screws, secure the modules on both sides to the wall.

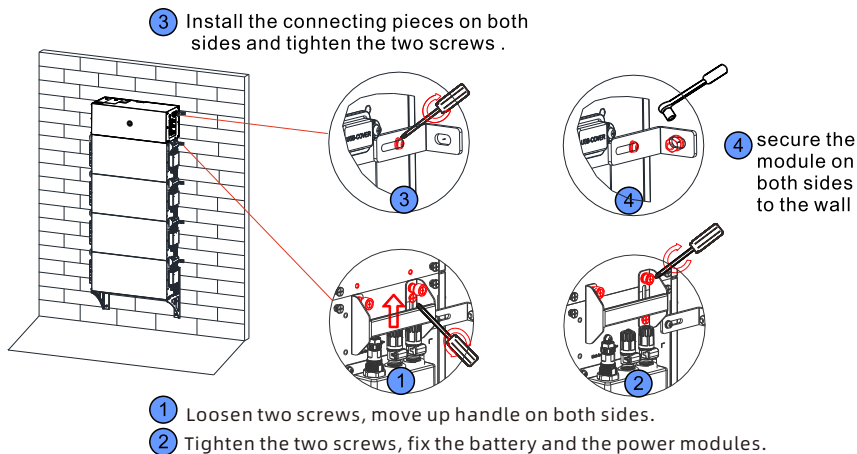

Figure 4-13: Install the power module

Step 6: Install the power module, raise the battery module handles on both sides, tighten the two screws that secure the power module and battery module. Install the connecting pieces on both sides and tighten the two screws, secure the module on both sides to the wall.



NOTICE

- The number of the battery module in wall-mounted installation should not exceed four (not including the power module).
- If there are more than four battery modules, please install them in two columns, and the clearance should be greater than or equal to 300mm.

4.3.3 Floor-mounted Installation

Mounting Hole Dimensions

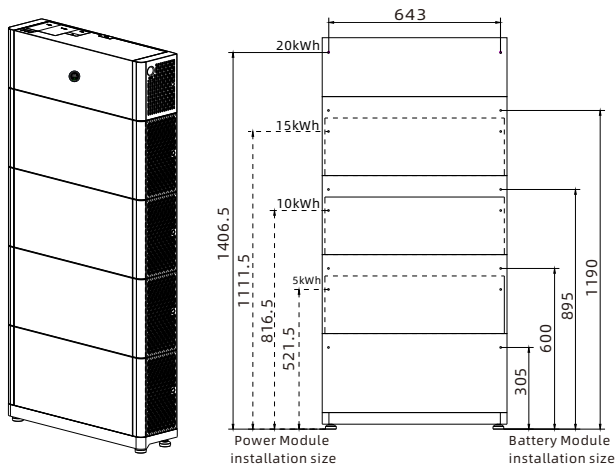
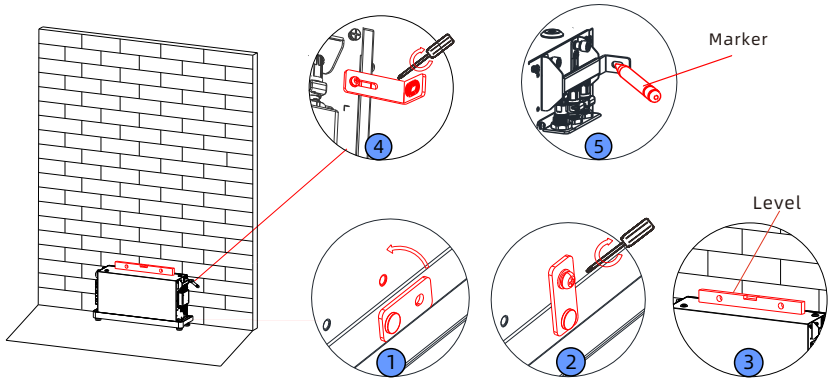

Figure 4-14: Mounting Hole Dimensions



- ① ② Install the connecting pieces on both sides and tighten the two screws.
- ④ Install the anti-tipping plates on both sides and tighten the two screws.
- ③ Keep the Battery Module level.
- ⑤ Mark the hole positions for installing the module.

Figure 4-15: Installing the battery support

Step 1: Install connecting pieces on both sides of the battery support and tighten the two screws. Place the first battery module on the floor support and keep the module level. Install the anti-tipping plates on both sides and tighten the two screws. Mark the hole positions for installing the battery module.

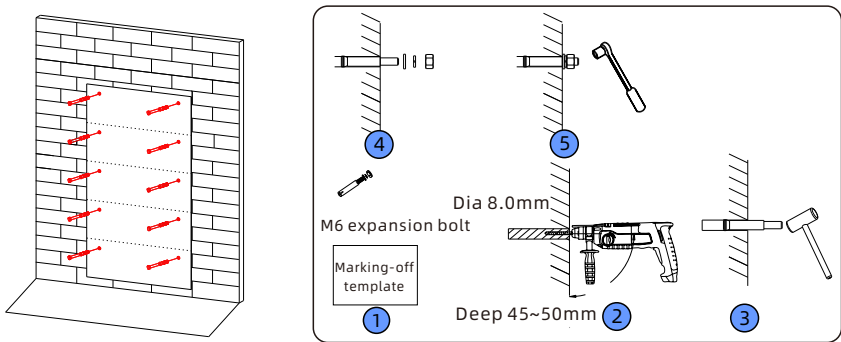

- ① The marking-off template ensures that the alignment marks are properly placed on the wall.
- ② ③ ④ ⑤ Fix the M6 expansion bolt into the wall.

Figure 4-16: The marking-off template and install the expansion bolt

Step 2: Move away the battery module, determine the hole positions to mount the battery modules from bottom to top using the marking-off template, mark the hole positions using a marker. Drill holes using the impact drill (alloy drills with a diameter of 8mm; the hole depth: 45mm to 50mm). Install the M6 expansion bolts.

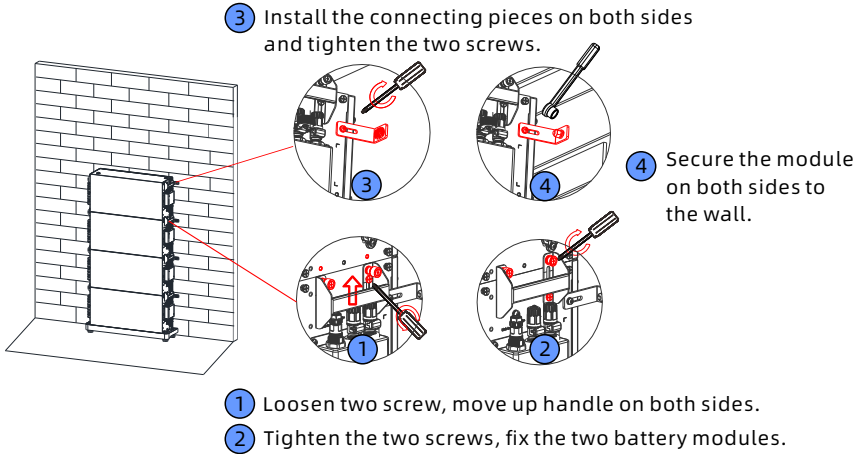

Figure 4-17: Install the battery module

Step 3: Install the remaining battery modules (no more than 4 of them), raise the handles on both sides, tighten the two screws that secure the battery module. Install the connecting pieces on both sides and tighten the two screws, secure the modules on both sides to the wall.

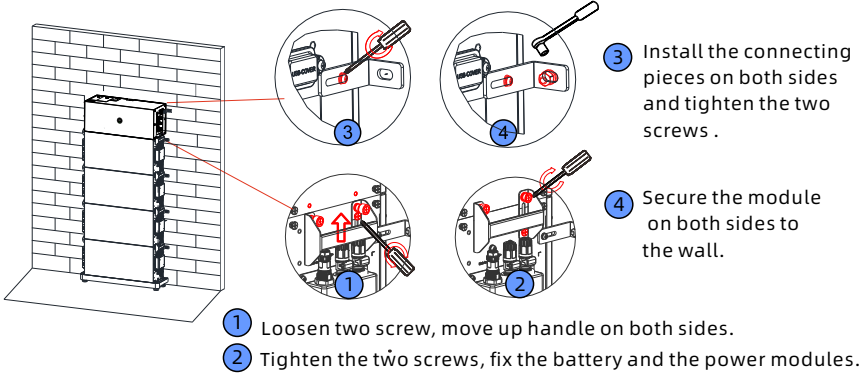

Figure 4-18: Install the power module

Step 4: Install the power module, raise the battery module handles on both sides, tighten the two screws that secure the power module and battery module. Install the connecting pieces on both sides and tighten the two screws, and secure the module on both sides to the wall.



NOTICE

- The number of the battery module in wall-mounted installation should not exceed four (not including the power module).
- If there are more than four battery modules, please install them in two columns, and the spacing should be greater than or equal to 300mm.

4.4 Electrical Connection



WARNING

Do not forget to wear ESD wrist strap and gloves, safety gloves and goggles.

4.4.1 Communication port definition

APX 5.0-30.0P-S0			MIN 2.5-6KTL-XH/MIN 2.5-6KTL-XH2		
Silk screen	Terminal serial number	Definition	Silk screen	Terminal serial number	Definition
INV	1	WAKE-(W-)	SYS COM	1	Enable-
	2	WAKE+(W+)		2	Enable+
	7	RS485_B(B)		7	BAT_B
	8	RS485_A(A)		8	BAT_A

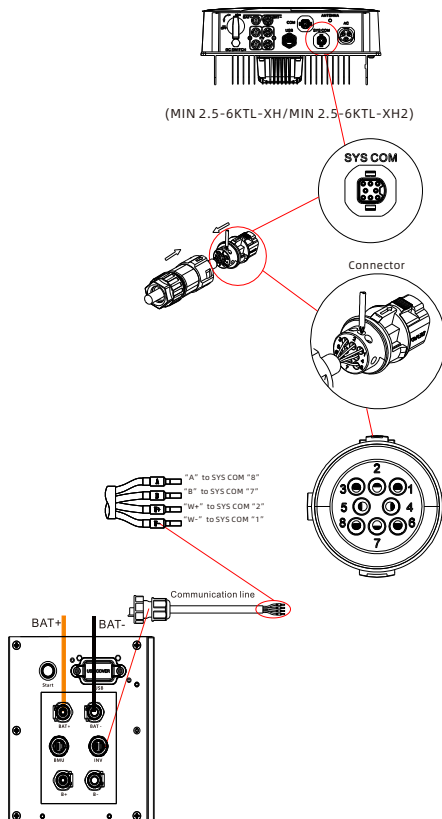

4.4.2 System connection



NOTICE

- A DC switch (switch-disconnector) has been installed in the Power Module. Therefore, a DC circuit breaker is not recommended to be installed between the battery system and the hybrid inverter system. If you have installed a DC circuit breaker, do not perform operations on the DC circuit breaker with power-on, otherwise the machine may be damaged. And you need to purchase the breaker with the following specifications by yourself:
 - a. Voltage: 600Vdc
 - b. Current: 32A

4.4.2.1 Battery Capacity Description

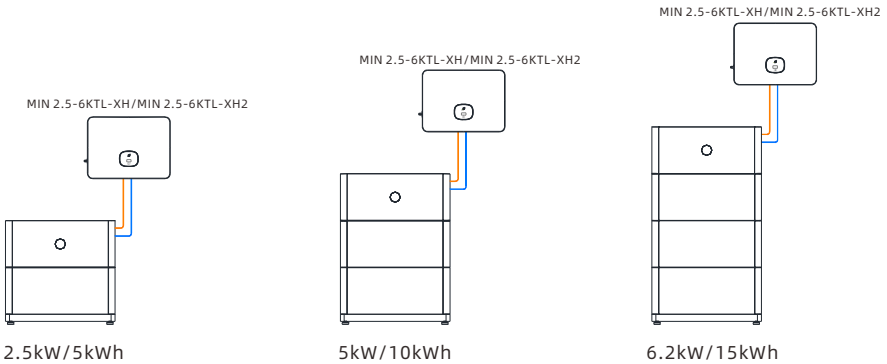

Figure 4-19: Installation diagram of the battery system with a battery capacity of 5kWh to 15kWh

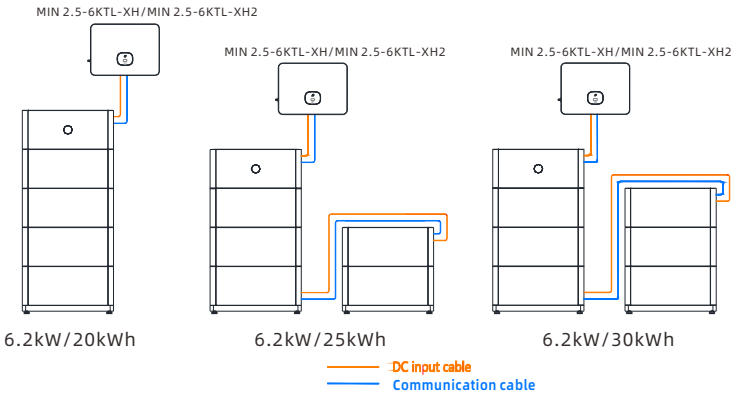

Figure 4-20: Installation diagram of the battery system with a battery capacity of 20kWh and 30kWh

Fig 4-20 Note:

When installing in two columns, please purchase two bases and the parallel extension cables, which include power cables, communication cables, and ground cables.

4.4.2.2 System connection diagram

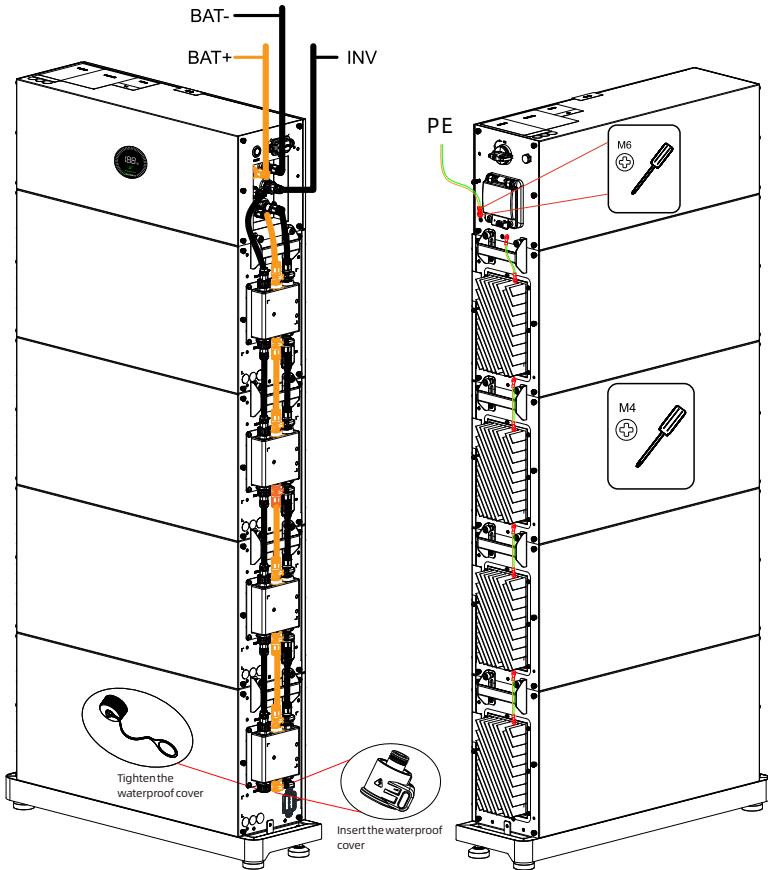
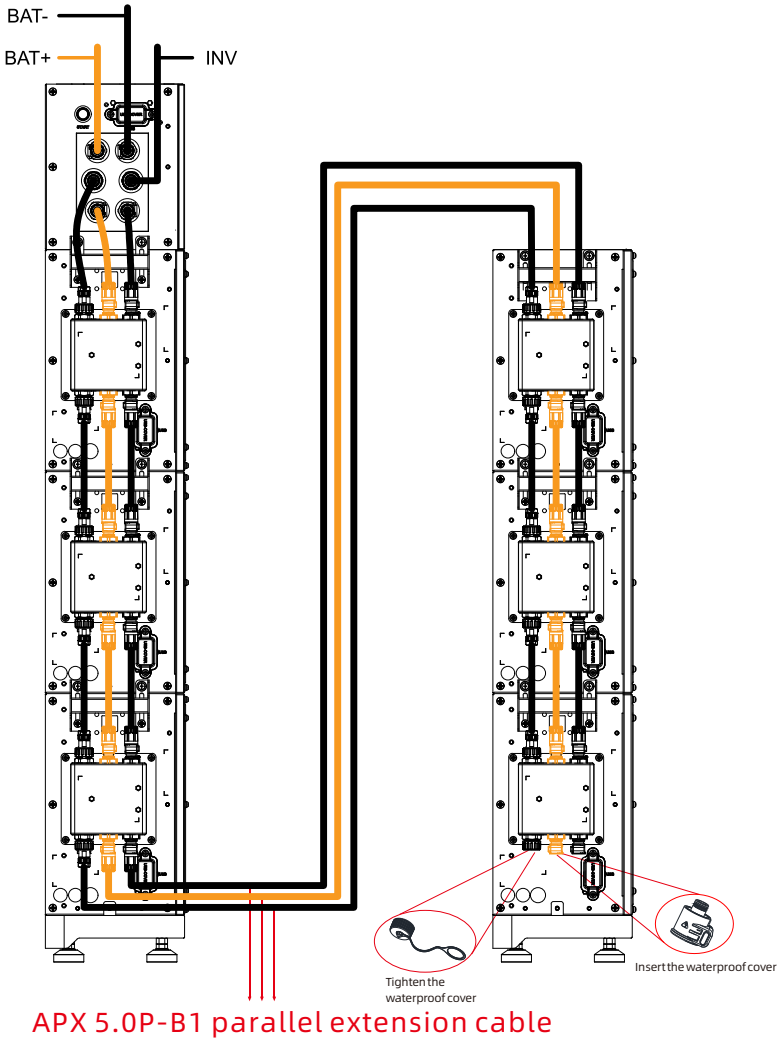

Figure 4-21: Single-column installation

Note:

The battery is not allowed to be installed when the machine is running. Ensure that all the lights indicating "RUN" of battery modules are off before installation. Ensure that the PE cable is securely connected.



Wiring sequence:

Grounding cable \Rightarrow Communication cable \Rightarrow Power cable

Figure 4-22: Two-column installation

- Note:** 1. Battery modules must be paralleled with B+ to B+, B- to B-.
2. When wiring the communication cable, remember to tighten the protective cover of the communication cable; otherwise it might undermine the waterproof performance. (Water penetration caused by failure to do so is beyond the scope of warranty.)

4.4.2.3 Electrical wiring connection

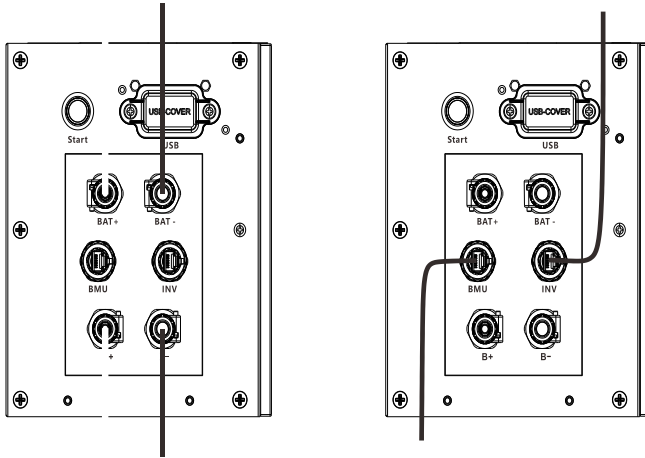

Figure 4-23: APX 55027-P0 wiring diagram

A. APX 55027-P0 (Power Module) wiring

- Step 1: Insert the power cable into the corresponding port. The click sound indicates a robust connection. The power cables are delivered with the Power Module.
- Step 2: Insert the communication cable into the "INV" port and "BMU" port, and then tighten the communication terminal clockwise. The INV communication port is used for communication connection with the hybrid inverter, and the BMU communication port is used for communication connection with the Battery Module by connecting to the "Link-in" port of the Battery Module. The communication cables are delivered with the Power Module.



NOTICE

- For a single APX battery system, the “Link-in” and “Link out” port of the Power Module don't need to be connected as they are only used for cascading the APX battery systems. For the cascaded system, connect the “Link out” port of the Power Module to the “Link in” port of another Power Module. Please pay attention to the connector color when connecting the power cables. Stick to the color conventions - orange to orange and black to black.
- Ensure that the PE cable is securely connected.
- This area is a restricted access area, which is explained below:
 - Area accessible only to electrically skilled persons and electrically instructed persons with the proper authorization.
 - Note 1 to entry: An electrically skilled person is a person who has received special education and adequate training in safety rules for the operation of the electrical installations.
 - Note 2 to entry: An electrically instructed person is a person who are informed of the safety rules for operating electrical equipment and can perform some operations under the supervision of skilled persons.

B. APX 5.0P-B1 (Battery module) wiring

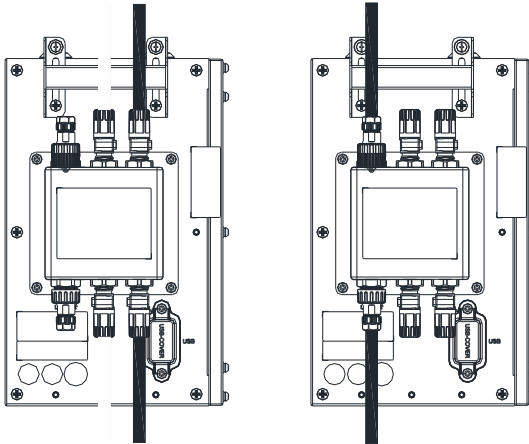

Figure 4-24: APX 5.0P-B1 wiring diagram

Step 1: Insert the power cable into the corresponding port. The click sound indicates a robust connection.

Step 2: Insert the communication cables into the "Link-in" and "Link out" port, and then tighten the communication terminals clockwise.

Step 3: The "Link out" port of the last battery module does not need to be connected. Tighten the dust cover.



NOTICE

- The last battery module refers to the battery module that is the most distant from the power module.
- Please pay attention to the connector color when connecting the power line. Stick to the color conventions - orange to orange and black to black.

4.4.2.4 External Electrical Connections of the APX

Step 1: Cut the cable hole according to the wiring mode.

Step 2: Cover it with a protective rubber ring, and route external cables through the cable hole.

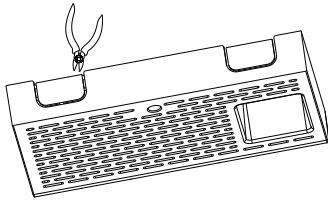

APX 55027-P0 Left trim-cover

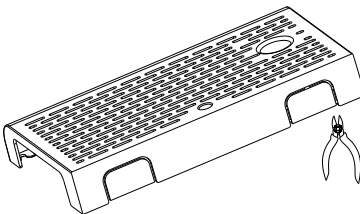
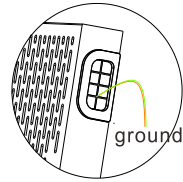
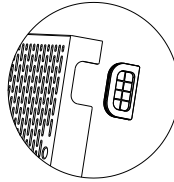

APX 55027-P0 Right trim-cover

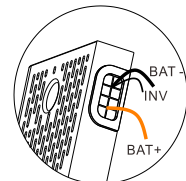
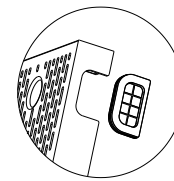

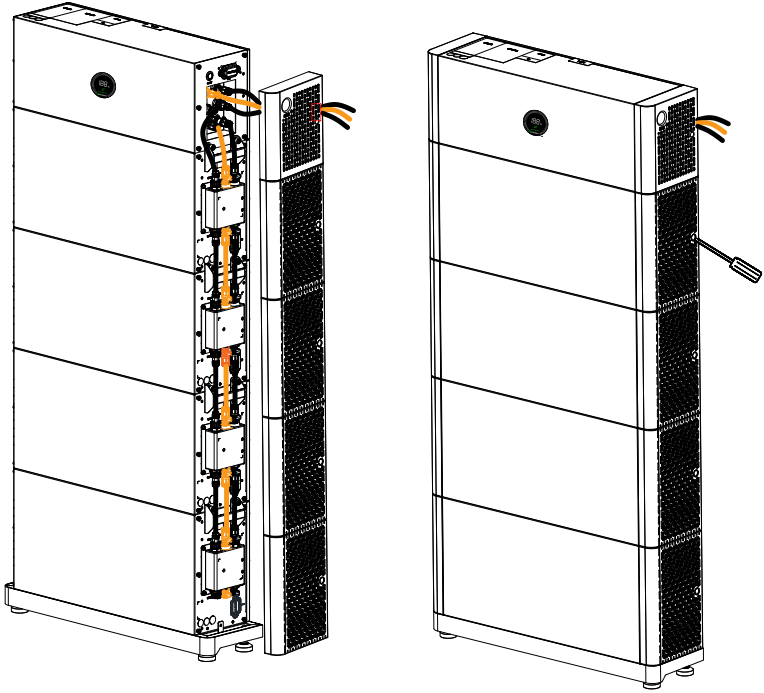

Figure 4-25: Installing external cables

Power on/off the APX Battery 5 System



NOTICE

- Personnel who install and operate the Battery System must receive thorough training and possess the local national required qualifications before operation. Only qualified professionals and trained personnel are allowed to install, operate and maintain the equipment.
- Please stand on dry insulating objects and do not wear conductive material such as watches and necklace during operation. Insulated tools should be used.
- Avoid contact with any parts with electric potential difference.
- Hang the warning sign: Do not touch. Authorized personnel only.
- If abnormality is found when the equipment is energized, turn off the DC switch of the power module immediately. After the fault is rectified, turn on the switches again.
- Make sure the inverter is off before checking the APX battery system.
- When connected to an inverter, the APX 5.0-30.0P-50 high voltage battery system can be monitored via RS485 communication. If an external monitoring module (optional) is used, such as Shine WIFI-X, Shine, Shine LINK-X, and Shine LAN-X, you can monitor the battery modules via the server remotely.

5.1 Power on the APX Battery System

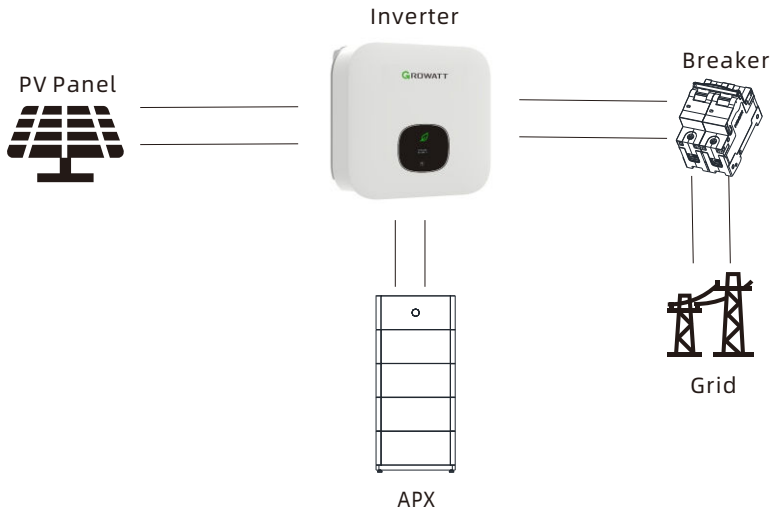

Figure 5-1

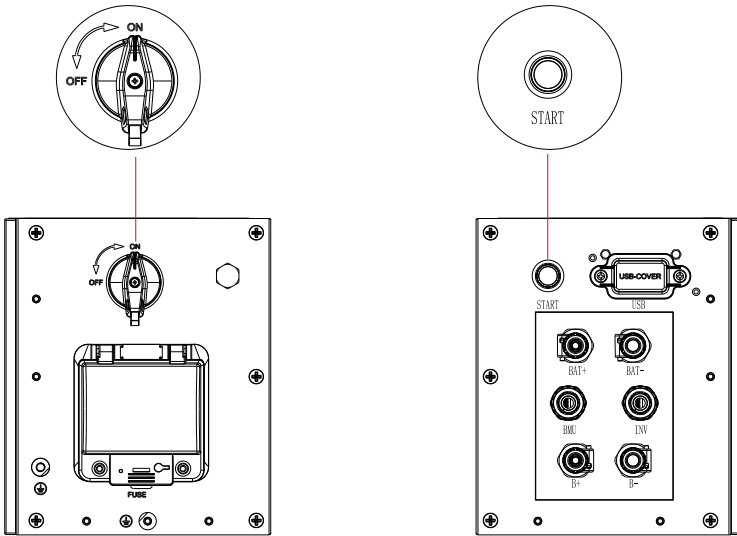

Figure 5-2

➤ Before turning on the battery, please check if the cable is properly connected.

Power on the APX battery system:

Step1: Turn on the DC switch of the Power Module.

Step2: Close the circuit breaker connecting the inverter and the load on the back-up box (if the inverter is connected to the back up box).

Step3: Close the circuit breaker connecting the inverter to the grid.

Step4: Turn on the DC switch of the inverter.

Step5: Press the POWER button and hold for three to eight seconds.

Step6: Observe the LED on the Power Module and inverter.



NOTICE

➤ In case that the switch is OFF when energizing the equipment, do not turn it on immediately; otherwise, the fuse may be damaged. The APX battery system will automatically shut down in a few minutes after the LED indicator and the logo “Growatt” go off. Do not turn on the switch until it is completely powered off.

5.2 Power off the APX Battery System

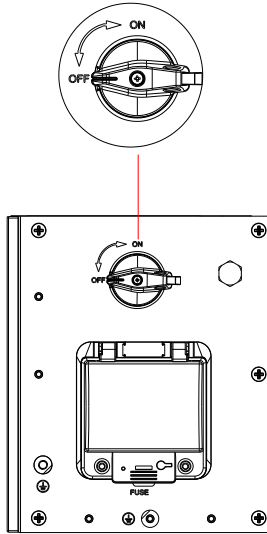

Figure 5-3

1. Turn off the DC switch on the APX, and disconnect the AC circuit breaker and the PV switch of the inverter.
2. Wait for 15 minutes until the LOGO indicator (GROWATT) on the APX turns off, indicating that the system is completely powered off.



NOTICE

- The APX battery system cannot be restarted until it is powered off completely.

6 Maintenance Guide

6.1 Preparation

After the system is powered off, the remaining electricity and heat still exist in the chassis, which may cause electric shocks or burns. Therefore, you need to wear protective gloves and perform operations 10 minutes after the system is powered off.

6.2 Replace a fuse

Step 1: Power off the APX system.

Step 2: Loosen the screws on the fuse shell.

Step 3: Lift the fuse box opening, remove the fuse, insert a new fuse into the slot, and close the fuse box.

Step 4: Tighten the screws on the fuse shell.

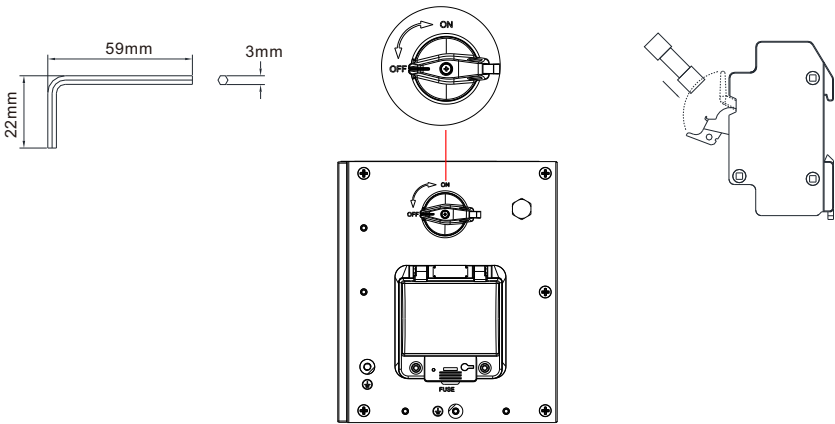

Figure 6-1: Replace a fuse



NOTICE

- After the system is powered off, the remaining electricity and heat still exist in the chassis, which may cause electric shocks or burns. Therefore, you need to wear protective gloves and perform operations 10 minutes after the system is powered off.

6.3 Battery Module or Power Module replacement

- Wear safety gloves.
- Turn off the switches to power off the battery system and wait for 10 minutes.
- Remove the trim covers on both sides.
- Disconnect power cables and CAN communication cables of the battery system.
- Wall-mounted battery system: unscrew the safety screws on both sides of the battery pack or the high voltage controller. Lift up the battery pack or the high voltage controller.

- Floor-mounted battery system: unscrew the safety screws on both sides of the battery pack or the high voltage controller. Lift up the Battery Module or the Power Module.
- Put the battery pack or the high voltage controller back into the packing case according to the repair procedures and transport the Battery Module or the Power Module to the designated site.
- Install new Battery Module or Power Module following the procedures specified in Section 4.

 NOTICE	<ul style="list-style-type: none"> ➤ The Battery Module contains batteries. Dispose of them in compliance with local laws and regulations. ➤ If the LED indicators are not displayed, you can tap the enclosure below the display to activate the screen.
--	---

6.4 LED indicators





			Meaning 指示含义
Steady white 白灯常亮	Blinking green at long intervals 绿灯慢闪	Steady green 绿灯常亮	Standby mode 待机模式
Blink in a clockwise direction 顺时针转	Steady green 绿灯常亮	N/A	Charging mode 充电模式
Blink in an anti-clockwise direction 逆时针转	Steady green 绿灯常亮	N/A	Discharge mode 放电模式
N/A	Blinking green at short intervals 绿灯快闪	N/A	Alarm 告警
N/A	Steady red 红灯常亮	N/A	System failure 系统故障
N/A	Blinking red at long intervals 红灯慢闪	Steady red 红灯常亮	Battery module failure 电池模块故障
8 LED indicators blink clockwise and "UP" is displayed 8个LED顺时针转和数量显示UP	N/A	N/A	Upgrade 升级
Off	Off	Off	Hibernation mode 休眠模式
Blinking green at short intervals (on for 0.5s and then off for 0.5s, on for 0.5s and then off for 2s) 绿灯快闪(亮0.5s,灭0.5s/亮0.5s,灭2s)			
Blinking green at long intervals (on for 0.5s and then off for 2s) 绿灯慢闪(亮0.5s,灭2s)			
Blinking red at long intervals (on for 1s and then off for 1s) 红灯慢闪(亮1s,灭1s)			

Figure 6-2: LED indicators

6.5 Troubleshooting

Indicator	Description	Cause	Measures
ALM			
 (Red Light on) Power Module	To PCS Communication failure	Communication loss between PCS and the APX battery system	1. There is no safety risk. 2. Ensure that the inverter is powered on. 3. Check if the PCS and battery communication terminals are well connected. 4. If the problem persists, users should contact the installer to repair the battery.
	To Battery Module Communication failure	Communication loss between the Power Module and the Battery Module	Check whether the communication cable between the Power Module and the Battery Module is securely connected.
	BUS Short-circuit	Power cable is short-circuited	Check if the positive and negative terminals are reversely connected.
	Power cable connection failure	The power cable is disconnected to the inverter	1. Check whether the power cable between the Power Module and PCS is securely connected. 2. Check if the switch is turned to the position "ON". 3. Check the fuse.
	High temperature protection	The temperature exceeds the BMS protection value	Stop using the battery immediately. Wait until the battery cools down and the alarm will disappear.
	Low temperature protection	The temperature is below the protection value	No safety hazard. Wait for the temperature to rise and the alarm will disappear.

Indicator	Description	Cause	Measures
ALM			
 (Red Light on) Battery Module	Power cable disconnected	The power cable is disconnected to the Power Module	Check whether the power cable between the Power Module and the Battery Module is securely connected.
	External communication failure	The external communication cable is not properly connected	1. Check whether the communication cable is securely connected. 2. Replace a communication cable.
	Voltage sampling anomaly protection	BMS voltage sampling failure	1. There is a safety risk and users should stop using the battery. 2. Users should contact the installer to repair the battery.
	Current sampling fault	BMS current sampling failure	
	Main circuit fault	BMS main power circuit failure	1. There is a safety risk and users should stop using battery. 2. Users should contact the installer to repair the battery.
	EEPROM fault protection	BMS MCU fails to receive data from EEPROM	1. There is a safety risk and users should stop using the battery. 2. Users should contact the installer to repair the battery.
	Chip fault protection	Communication loss between two MCUs	1. There is a safety risk and users should stop using the battery. 2. Users should contact the installer to repair the battery.
	Discharge under voltage protection	Single cell voltage is below the threshold for under-voltage protection	1. There is a safety risk due to over discharging. 2. Users should stop discharging the battery and recharge the battery after the fault is rectified.
	Charge over voltage protection	Single cell voltage exceeds the threshold for over-voltage protection	1. There is no safety risk. 2. Users should stop charging the battery and the alarm will disappear.

6.6 System fault information list and troubleshooting suggestions

PM (Power Module) Fault Code List

Error Code	Description	Suggested measures
FAULT 404(0)	BM to PM undervoltage	Power off the machine and check the power cables, then restart the machine. If the problem persists, please contact Growatt support.
FAULT 406(0)	BM to PM transient overvoltage	Power off the machine and check the power cables, then restart the machine. If the problem persists, please contact Growatt support.
FAULT 407(0)	BM to PM open-circuited	Power off the machine and check the power cables between BM and PM, then restart the machine. If the problem persists, please contact Growatt support.
FAULT 408(0)	Over-Temp	Power off the machine and wait for 30 minutes before you restart the machine. If the problem persists, please contact Growatt support.
FAULT 409(2)	PM to INV transient overvoltage	Power off the machine and check the power cables, then restart the machine. If the problem persists, please contact Growatt support.
FAULT 411(0)	Abnormal communication with INV	Power off the machine and check the communication cables between PM and INV, then restart the machine. If the problem persists, please contact Growatt support.
FAULT 411(1)	Abnormal serial communication with the master control chip	Power off the machine and check the communication cables between PM and PM, then restart the machine. If the problem persists, please contact Growatt support.
FAULT 411(2)	Abnormal communication with BM	Power off the machine and check the communication cables between BM and PM, then restart the machine. If the problem persists, please contact Growatt support.
FAULT 411(5)	Abnormal communication with BM	Power off the machine and check the communication cables between BM and PM, then restart the machine. If the problem persists, please contact Growatt support.
FAULT 411(7)	Multiple Masters parallel communication failure	Power off the machine and check the communication cables between BM and BM, then restart the machine. If the problem persists, please contact Growatt support.

Error Code	Description	Suggested measures
FAULT 416(1)	Transient overvoltage/ overcurrent	Power off the machine and check the power cables, then restart the machine. If the problem persists, please contact Growatt support.
FAULT 416(2)	Transient overcurrent	Power off the machine and check the power cables, then restart the machine. If the problem persists, please contact Growatt support.
FAULT 416(4)	BM to PM overcurrent	Power off the machine and check the power cables, then restart the machine. If the problem persists, please contact Growatt support.
FAULT 417(0)	Mismatched communication protocol version	Please contact Growatt support.
FAULT 417(1)	Mismatched MODEL of software/ hardware	Please contact Growatt support.
FAULT 419(5)	Inconsistent hardware/ software version	Please contact Growatt support.
FAULT 500(3)	CAN parallel connection failed	Power off the machine and check the communication cables between PM and PM, then restart the machine. If the problem persists, please contact Growatt support.
FAULT 505(0)	PM to INV voltage calibration failed	Power off the machine and check the power cables between PM and INV, then restart the machine. If the problem persists, please contact Growatt support.
FAULT 506(1)	PM circuit breaker open-circuited	Power off the machine and check the insulation breaker, then restart the machine. If the problem persists, please contact Growatt support.
FAULT 506(2)	PM fuse open-circuited	Please contact Growatt support.
FAULT 506(3)	PM to INV short-circuited (power cables reversed)	Power off the machine and check the power cables between PM and INV, then restart the machine. If the problem persists, please contact Growatt support.
FAULT 508(3)	Transient overvoltage	Power off the machine and check the power cables, then restart the machine. If the problem persists, please contact Growatt support.

Error Code	Description	Suggested measures
FAULT 603(0)	PM to INV voltage soft start failed	Power off the machine and check the power cables between PM and INV, then restart the machine. If the problem persists, please contact Growatt support.
FAULT 603(1)	PM to INV voltage soft start failed	Power off the machine and check the power cables between PM and INV, then restart the machine. If the problem persists, please contact Growatt support.
FAULT 700(0)	Temperature sensor open-circuited	When the temperature of the machine is close to -40°C (-40°F), it will raise this alarm. If the temperature is higher than -40°C(-40°F) when this alarm is reported, please contact Growatt support.
FAULT 707(0)	Overload fault	Reduce the load power, then restart the machine. If the problem persists, please contact Growatt support.
FAULT 707(2)	Overload fault	Reduce the load power, then restart the machine. If the problem persists, please contact Growatt support.
WARN 404(0)	Abnormal EEPROM	Please contact Growatt support.
WARN 410(0)	External oscillation abnormal	Restart the machine. If the problem persists, please contact Growatt support.
WARN 410(1)	Oscillation abnormal	Restart the machine. If the problem persists, please contact Growatt support.
WARN 410(2)	USB communication abnormal	Restart the machine, and replace the USB flash drive. If the problem persists, Please contact Growatt support.
WARN 411(6)	Parallel communication failed	Power off the machine and check the communication cables between PM and PM, then restart the machine. If the problem persists, please contact Growatt support.
WARN 417(2)	BM and PM software version mismatched	BM and PM will automatically update to the matched software version (takes about 30 minutes). If the problem persists, Please contact Growatt support.
WARN 431(0)	BOOT abnormal	Please contact Growatt support.

Error Code	Description	Suggested measures
WARN 500(0)	Abnormal CAN communication during parallel operation	Power off the machine and check the communication cables between PM and PM, then restart the machine. If the problem persists, please contact Growatt support.
WARN 500(7)	BM went offline	Power off the machine and check the communication cables between BM and BM, then restart the machine. If the problem persists, please contact Growatt support.
WARN 500(9)	Abnormal communication with PM	Power off the machine and check the communication cables between PM and PM, then restart the machine. If the problem persists, please contact Growatt support.
WARN 701(0)	Battery not discharging alarm	The battery SOC reaches the preset discharge cutoff SOC. Therefore, the battery is not allowed to discharge.
WARN 702(0)	Forced charge is required	The battery SOC is lower than the preset discharge cutoff SOC. Therefore, forced charge is required.
WARN 703(0)	Battery is fully charged	The battery SOC reaches the preset charge cutoff SOC. Therefore, the battery is not allowed to be charged.
WARN 704(0)	PM to INV overvoltage	Power off the machine and check the power cables between PM and INV, then restart the machine. If the problem persists, please contact Growatt support.
WARN 705(0)	PM to INV overvoltage	Power off the machine and check the power cables between PM and INV, then restart the machine. If the problem persists, please contact Growatt support.
WARN 707(1)	Discharge Overload Alarm	Reduce the load power, then restart the machine. If the problem persists, please contact Growatt support.
WARN 708(0)	Discharge Overload Anomaly	Reduce the load power, then restart the machine. If the problem persists, please contact Growatt support.



NOTICE

➤ The above table is the Songshan Lake series fault and warning code, different products have slight differences.

BM (Battery Module) Fault Code List

Error Code	Description	Suggested measures
FAULT 408(0)	Over-Temp	Power off the machine and wait for 30 minutes before you restart the machine. If the problem persists, please contact Growatt support.
FAULT 409(2)	BM transient overvoltage	Power off the machine and check the power cables, then restart the machine. If the problem persists, please contact Growatt support.
FAULT 410(0)	External oscillation abnormal	Restart the machine. If the problem persists, please contact Growatt support.
FAULT 411(1)	Abnormal serial communication	Power off the machine and check the communication cables between BM and BM, then restart the machine. If the problem persists, please contact Growatt support.
FAULT 411(5)	Abnormal communication with PM	Power off the machine and check the communication cables between BM and PM, then restart the machine. If the problem persists, please contact Growatt support.
FAULT 411(6)	Parallel connection failed	Power off the machine and check the communication cables between BM and BM, then restart the machine. If the problem persists, please contact Growatt support.
FAULT 411(7)	Multiple Masters parallel connection failure	Power off the machine and check the communication cables between BM and BM, then restart the machine. If the problem persists, please contact Growatt support.
FAULT 416(1)	Transient overvoltage/overcurrent	Power off the machine and check the power cables, then restart the machine. If the problem persists, please contact Growatt support.
FAULT 416(5)	Transient overvoltage	Power off the machine and check the power cables, then restart the machine. If the problem persists, please contact Growatt support.
FAULT 416(6)	Transient overvoltage	Power off the machine and check the power cables, then restart the machine. If the problem persists, please contact Growatt support.

Error Code	Description	Suggested measures
FAULT 417(0)	Inconsistent communication protocol versions	Please contact Growatt support.
FAULT 419(5)	Inconsistent software/hardware versions	Please contact Growatt support.
FAULT 431(0)	BOOT abnormal	Please contact Growatt support.
FAULT 500(0)	CAN communication abnormal	Power off the machine and check the communication cables between BM and BM, then restart the machine. If the problem persists, please contact Growatt support.
FAULT 500(1)	CAN parallel connection failed	Power off the machine and check the communication cables between BM and BM, then restart the machine. If the problem persists, please contact Growatt support.
FAULT 501(0)	Battery fault	Restart the machine. If the problem persists, please contact Growatt support.
FAULT 502(0)	Battery undervoltage	Restart the machine. If the problem persists, please contact Growatt support.
FAULT 502(1)	BM undervoltage	Power off the machine and check the power cables, then restart the machine. If the problem persists, please contact Growatt support.
FAULT 503(0)	Battery overvoltage	Restart the machine. If the problem persists, please contact Growatt support.
FAULT 503(1)	Battery transient overcurrent	Restart the machine. If the problem persists, please contact Growatt support.
FAULT 505(0)	BM voltage calibration failed	Power off the machine and check the power cables, then restart the machine. If the problem persists, please contact Growatt support.
FAULT 603(2)	BM voltage calibration failed	Power off the machine and check the power cables, then restart the machine. If the problem persists, please contact Growatt support.

Error Code	Description	Suggested measures
FAULT 700(0)	Temperature sensor open-circuited	When the temperature of the machine is close to -40°C (-40°F), it will raise this alarm. If the temperature is higher than -40°C(-40°F) when this alarm is reported, please contact Growatt support.
FAULT 707(0)	Discharge Overload	Reduce the load power, then restart the machine. If the problem persists, please contact Growatt support.
WARN 410(1)	Oscillation abnormal	Restart the machine. If the problem persists, please contact Growatt support.
WARN 410(2)	USB communication abnormal	Restart the machine, and replace the USB flash drive. If the problem persists, Please contact Growatt support.
WARN 500(6)	CAN message from slave repeated	Power off the machine and check the communication cables between BM and BM, then restart the machine. If the problem persists, please contact Growatt support.
WARN 701(0)	Battery not discharging alarm	The battery SOC reaches the preset discharge cutoff SOC. Therefore, the battery is not allowed to discharge.
WARN 702(0)	Forced charge is required	The battery SOC is lower than the preset discharge cutoff SOC. Therefore, forced charge is required.
WARN 703(0)	Battery is fully charged	The battery SOC reaches the preset charge cutoff SOC. Therefore, the battery is not allowed to be charged.
WARN 704(0)	BM overvoltage	Power off the machine and check the power cables, then restart the machine. If the problem persists, please contact Growatt support.
WARN 705(0)	BM overvoltage	Power off the machine and check the power cables, then restart the machine. If the problem persists, please contact Growatt support.
WARN 707(1)	Discharge Overload Alarm	Reduce the load power, then restart the machine. If the problem persists, please contact Growatt support.

6.7 Cleaning

➤ Checking the heat dissipation

In case that output reduction of the APX battery system occurs regularly due to high temperature, please improve the heat dissipation conditions, such as cleaning the heat sink.

➤ Cleaning the APX battery system

If the enclosure of the battery system gets dirty, shut down the system and wait until it is completely powered off. Clean the enclosure and the display with a moistened cloth. Do not use any cleaning agents, e.g. solvents or abrasives.

➤ Checking the DC switch and cables

Check for any externally visible damage and discoloration of the DC switch and cables regularly. If any visible damage of the DC switch is found, or the cable is damaged or discolored, please contact the installer.

Turn the knob switch from On to Off 5 times in a row every year, which cleans the touch area of the knob switch and extends its electrical endurance.

7 Technical Specifications

7.1 APX 55027-P0 (Power Module)

No.	Items	Specifications
1	Model	APX 55027-P0
2	B+/B- voltage range	330V-450V
3	BAT+/BAT- voltage range	380-550V
4	Rated current	17A
5	Maximum current	27A
6	Temperature range	-10~50°C
7	IP rating	Ip66
8	Warranty	10 years
9	Communication method	CAN2.0
10	Dimensions (W/D/H)	690*185*220 mm ±2mm
11	Weight	10±1kg
12	Certification & Licensing	IEC62040/IEC62619/ IEC62477/CE/UKCA/UN38.3
13	Environment requirements	RoHS

7.2 APX 5.0P-B1 (Battery Module)

No.	Items	Specifications
1	Module	APX 5.0P-B1
2	Nominal Capacity/Energy	100Ah/5kWh
3	Rated Usable Capacity/Energy	100Ah/4.5kWh
4	Rated Voltage	385V
5	Operating Voltage	330-450V
6	Rated current (25°C)	7.6A
7	Maximum current (25°C)	12.5A
8	Battery Type	Cobalt Free Lithium Iron Phosphate (LFP)
9	Operating temperature range	-10~50°C
10	Storage conditions	40°C~50°C/7 days; -20°C~40°C/6 months; 5%-95%RH
11	Cooling	Natural cooling
12	Dimensions (W/D/H)	690/185/295mm±2mm
13	Weight	50±1kg

No.	Items	Specifications
14	Installation	Wall-mounted installation/ floor-mounted installation
15	Warranty	10 Years
16	IP rating	IP66
17	Certification & Licensing	IEC62040/IEC62619/ IEC62477/CE/UKCA/UN38.3
18	Environment requirements	RoHS

IFpP/51/161/119/[1P16S]M/-10+50/90

Formula for calculating the rated capacity:

Rated capacity of the measured module: 100 Ah

N (Number of modules connected in Parallel): 1~6

Rated capacity (Ah) = 100 Ah *N

Shenzhen Growatt New Energy Co., Ltd.

4-13/F, Building A, Sino-German (Europe) Industrial Park,
Hangcheng Blvd, Bao'an District, Shenzhen, China

T +86 755 2747 1942

E service@ginverter.com

W www.ginverter.com



**Download
Manual**



 **Growatt New Energy**

Shenzhen Growatt New Energy Co., Ltd.

4-13/F, Building A, Sino-German (Europe) Industrial Park,
Hangcheng Blvd, Bao'an District, Shenzhen, China

T +86 755 2747 1942

E service@ginverter.com

W www.ginverter.com

GR-UM-336-A-01 (PN:044.0128200)